

Typ P - velká kladka / P type - plain roller

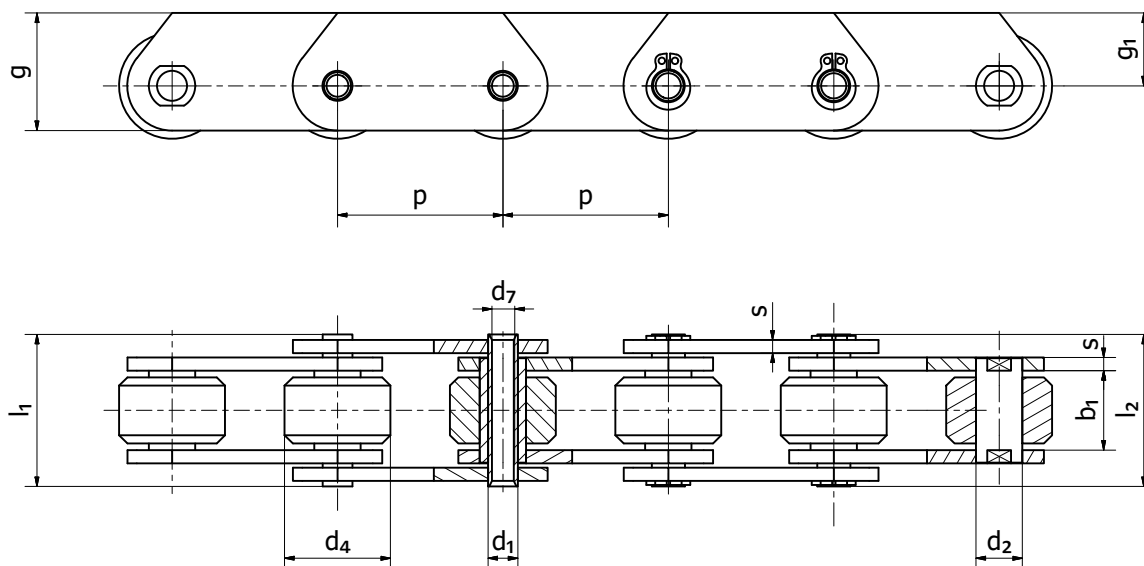

Dopravníkové řetězy série FVCT dle DIN 8165
 Conveyor chains FVCT series according to DIN 8165

Označení	Rozteč								Vnitřní šířka	Průměr pouzdra	Průměr kladky	Rozměry desky			Rozměry čepu			Pevnost při přetížení	
												Šířka	Výška	Tloušťka	Vnější průměr	Vnitřní průměr	Délka		
Reference	Pitch								Inner width	Bush diameter	Roller diameter	Plate dimensions			Pin dimensions			Breaking load	
ISO	p								b1 min	d2 max	d4 max	g max	g1	s max	d1 max	d7 min	l1 max	l2 max	Fb min
	mm	mm	mm	mm	mm	mm	mm	mm	mm	mm	mm	mm	mm	mm	mm	mm	mm	mm	kN
FVCT-63	50	63	80	100	125	160	200	-	22	18	40	40	25,0	4	12	8,2	46	55	46
FVCT-90	50	63	80	100	125	160	200	250	25	20	48	45	27,5	5	14	10,2	53	62	55
FVCT-112	80	100	125	160	200	250	315	-	30	22	55	50	30,0	6	16	11,2	63	72	78
FVCT-140	80	100	125	160	200	250	315	400	35	26	60	60	37,5	6	18	12,2	68	80	105
FVCT-180	-	100	125	160	200	250	315	400	45	30	70	70	45,0	8	20	14,3	86	100	118
FVCT-250	-	-	125	160	200	250	315	400	55	36	80	80	50,0	8	26	18,3	98	114	206
FVCT-315	-	-	125	160	200	250	315	400	65	42	90	90	55,0	10	30	20,3	117	133	290