

Dopravníkové řetězy série M • Conveyor chains M series

Typ B - bez kladek / B type - without rollers

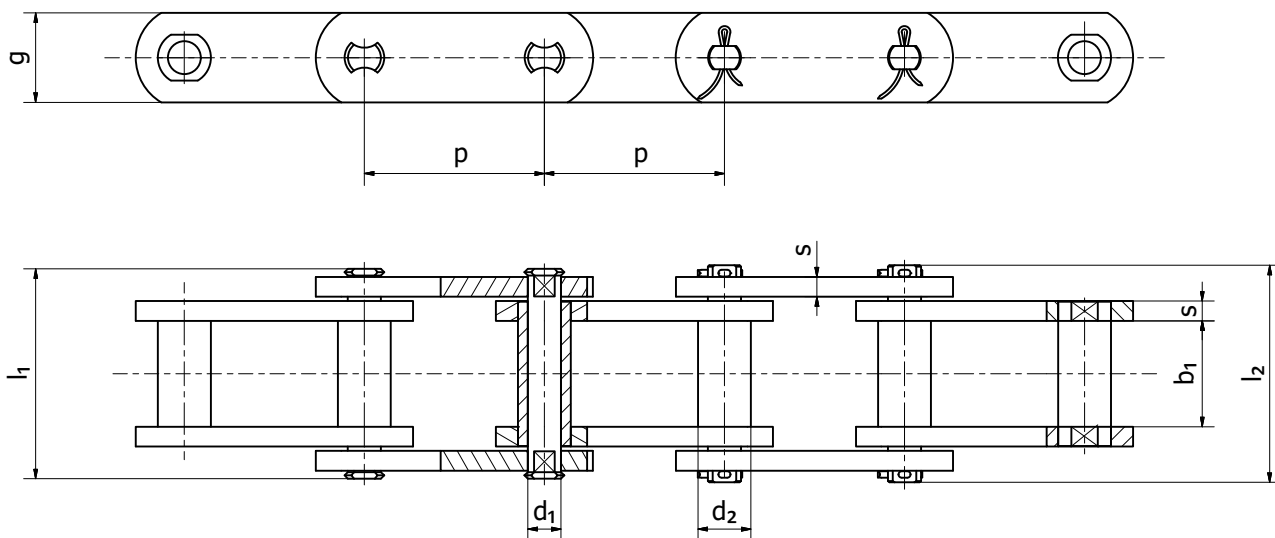

Typ S / S type

Kladky / Rollers
Typ P / P type

Typ F / F type

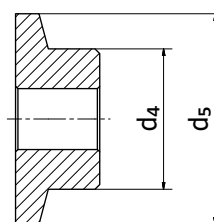
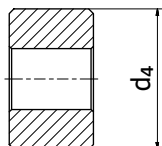
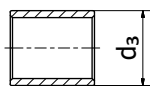

Malá kladka / Small roller

Velká kladka / Plain roller

Kladka s nákolkem / Flanged roller

Dopravníkové řetězy série M dle DIN 8167, ISO 1977, ČSN 26 0401

Conveyor chains M series according to DIN 8167, ISO 1977

Označení	Rozeč						Vnitřní šířka	Průměr pouzdra	Průměr kladky			Rozměry desky		Rozměry čepu		Pevnost při přetřetí		
									Malá	Velká	Nákolkem	Šířka	Tloušťka	Průměr	Délka			
Reference	Pitch						Inner width	Bush diameter	Roller diameter			Plate dimensions		Pin dimensions		Breaking load		
	p						b1 min	d2 max	d3 max	d4 max	d5 max	g max	s max	d1 max	l1 max		l2 max	Fb min
ISO	mm						mm	mm	mm	mm	mm	mm	mm	mm	mm	mm	mm	kN
M-20	40	50	63	80	100	125	160	16	9	12,5	25	30	18	2,5	6	35	49	20
M-28	50	63	80	100	125	160	200	18	10	15	30	36	20	3	7	40	56	28
M-40	63	80	100	125	160	200	250	20	12,5	18	36	42	25	3,5	8,5	45	63	40
M-56	63	80	100	125	160	200	250	24	15	21	42	50	30	4	10	52	72	56
M-80	80	100	125	160	200	250	315	28	18	25	50	60	35	5	12	62	86	80
M-112	80	100	125	160	200	250	315	32	21	30	60	70	40	6	15	73	101	112
M-160	100	125	160	200	250	315	400	37	25	36	70	85	50	7	18	85	117	160
M-224	125	160	200	250	315	400	500	43	30	42	85	100	60	8	21	98	134	224
M-315	160	200	250	315	400	500	630	48	36	50	100	120	70	10	25	112	154	315
M-450	-	200	250	315	400	500	630	56	42	60	120	140	80	12	30	135	185	450
M-630	-	200	250	315	400	500	630	66	50	70	140	170	100	14	36	147	200	630
M-900	-	-	250	315	400	500	630	78	60	85	170	210	120	16	44	167	220	900